

## Installation Guide

# FHR Internal Head Restraints

### Ancon FHR Internal Head Restraints

FHR Head Restraints provide the necessary restraint at the top of masonry walls. The smaller angle is fitted below the larger angle to form an “F” profile over the head of the blockwork taking care to line up the holes in both the smaller and larger profile. (The two holes in the larger profile are set for 100mm and 140mm thicknesses of masonry).

The two profiles are then bolted to the underside of the structure using the appropriate fixing.

### Position

FHR Head Restraints will typically be positioned at 450mm or 900mm centres depending on the expected load at the top of the wall. Each restraint can resist a maximum service load of 1.0kN.

The gap at the top of the wall to the underside of the structure above should not exceed 25mm.

### Fixings

Where FHR Head Restraints are fixed back to the underside of concrete soffits we recommend a M8 FBN Expansion Bolt be used. Where fixing to the underside of structural steelwork a M8 isolated setscrew should be used. Please contact us for tightening torques and allowable edge distances.

### Safety Precautions

Ancon stainless steel products are produced from sheared plate. As with all such industrial fabrications, these may present sharp edges. **Suitable personal protective equipment should be worn at all times during handling and installation.**

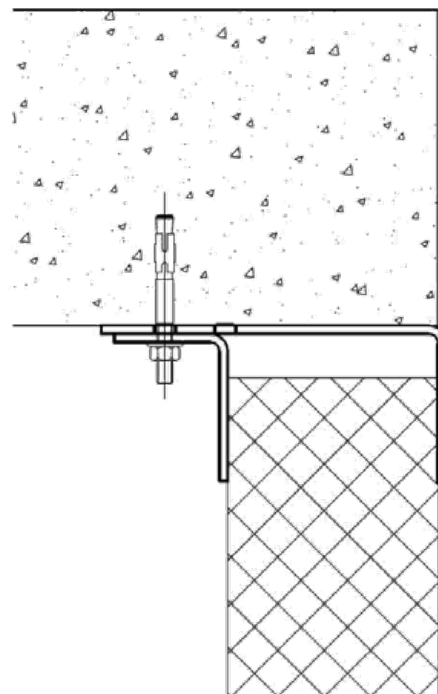
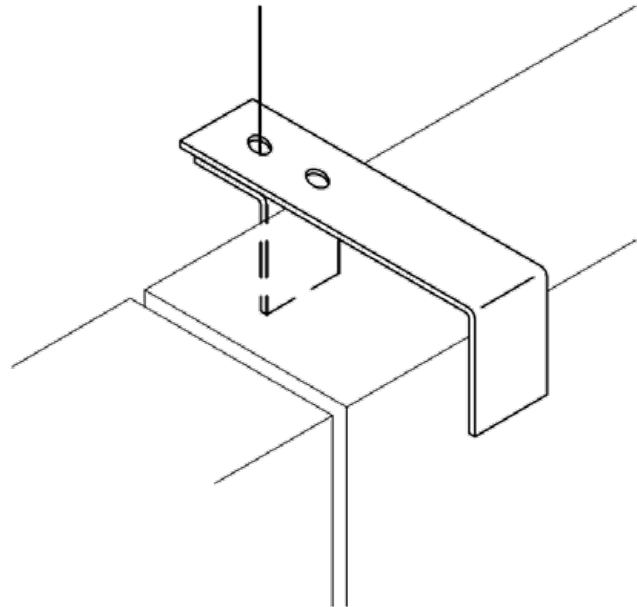

**Section Through**

© Leviat, 2020

The Construction applications and details provided in this guide are indicative only. In every case installation should be entrusted to appropriately qualified and experienced persons. Normal handling precautions should be taken to avoid physical injury. Leviat cannot be held responsible for any injury as a result of using our products, unless such injury arises as a result of our negligence.