



**COMPLIANT**  
AS 3850.1:2015



**Ancon**<sup>®</sup>  
**Unilift Lifting Systems**  
for the Precast Concrete Industry



# **We are one team.** **We are Leviat.**

Leviat is the new name of CRH's construction accessories companies worldwide.

Under the Leviat brand, we have united the expertise, skills and resources of Ancon and its sister companies to create a world leader in fixing, connecting and anchoring technology.

The products you know and trust will remain an integral part of Leviat's comprehensive brand and product portfolio. As Leviat, we can offer you an extended range of specialist products and services, greater technical expertise, a larger and more agile supply chain and better, faster innovation.

By bringing together CRH's construction accessories family as one global organisation, we are better equipped to meet the needs of our customers, and the demands of construction projects, of any scale, anywhere in the world.

**This is an exciting change. Join us on our journey.**

**Read more about Leviat at [Leviat.com](https://www.leviat.com)**



Our product brands include:

**Ancon**<sup>®</sup>

**Connolly**

**HALFEN**

**HELIFIX**

**ISEDIO**

**PLAKA**



**60**

locations

sales in  
**30+**  
countries

**3000**

people worldwide

Imagine. Model. Make.

[Leviat.com](https://Leviat.com)

# Unilift Lifting Systems



## Unilift Systems

Unilift is the ideal lifting and handling system for a wide variety of precast concrete products, particularly in civil engineering applications. The system is typically used for lifting panels, pipes, pits, manholes, road barriers, bridge beams, planks, sound walls, culverts etc.

The Ancon Unilift Lifting System consists of a range of lifting anchors, clutches and recess formers used for the safe, fast and efficient handling of a wide range of precast concrete items during manufacture, transport and installation. Unilift components are available in 6 load classes with working loads reaching from 1.3t - 32t.

Unilift CA Cone Anchors and Unilift RA Reo Anchors are forged headed anchors that are cast into the concrete. Recess formers create a spherical recess around the anchor head. Unilift LK Locking Klaws engage with the anchor head and transfer the lifting loads safely into the anchor. Unilift components of different load groups are not interchangeable for maximum safety.

### Locking Klaw

*Safety clutch which locks to the anchor head*

### Anchor

*Forged anchor set below the concrete surface*

### Recess

*Formed in the concrete by a recess former to permit attachment of the Locking Klaw to the anchor head.*



- ✓ Locking Klaw can be connected with the tail towards the load and the tail away from the load preventing unsafe situations caused by mis-engagement.
- ✓ Standard load classes of 1.3, 2.5, 5, 10, 20 and 32 tonnes available.
- ✓ Fast, efficient handling of products in the factory, during transport and on the job-site.
- ✓ Unique, patented design of the Unilift Locking Klaw prevents disconnection between clutch and anchor.
- ✓ Easy to train operators how to use the system with minimal supervision.
- ✓ Components of different load groups are not interchangeable for maximum safety.
- ✓ Unilift Locking Klaws and Anchors exceed the requirements for lifting systems in AS 3850.1:2015 - Prefabricated Concrete Elements
- ✓ Anchors are hot-dip galvanised for superior corrosion resistance.

## Unilift Locking Klaw

These strong, safe, lightweight clutches suit all spherical head lifting anchors. They protect against dangerous disconnection where there is a risk of fouling, which is a common problem when lowering precast drainage products into confined spaces like trenches. They also help to safely rotate civil prefabricated concrete units.

Unilift Locking Klaws are the strongest clutches on the market. Their capacity exceeds the factor of safety of 4.0 for lifting clutches as specified in AS 3850.1:2015, table 2.1.

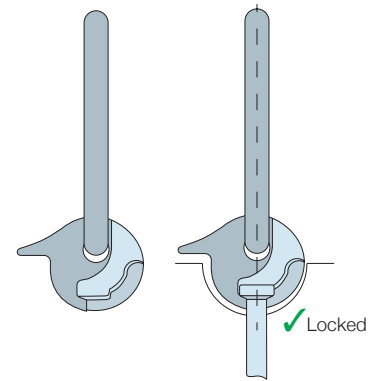

Locking Well interlocks with the Anchor Head

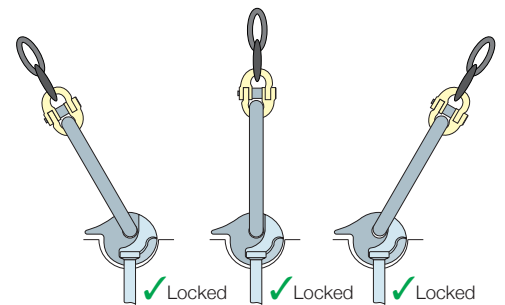
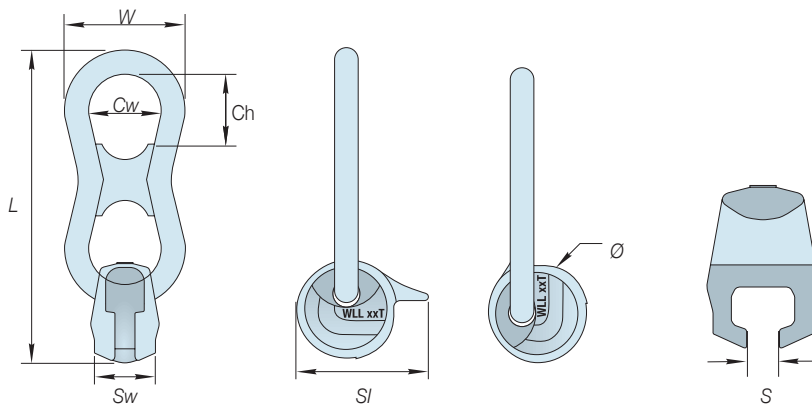

Unique design ensures safe engagement for all load directions

### Working Load Limits

WLL	Annual Proof Load kN	Nominal WLL Anchor	Part Code
2	24	1.3	01LK
3	36	2.5	02LK
5	60	5	05LK
10	120	10	10LK
20	240	20	20LK
32	384	32	32LK / 32LC*

### Part Codes and Nominal Dimensions

Part Code	Dimensions (mm)							
	L	W	Ch	Cw	Sw	SI	Ø	S
01LK	170	66	44	40	33	72	56	11
02LK	215	85	59	52	42	88	68	16
05LK	270	110	62	70	57	113	88	22
10LK	365	145	83	90	73	144	112	31
20LK	550	176	155	76	110	195	152	43
32LC*	680	272	189	172	160	300	180	52
32LK	850	286	291	166	155	233	182	55

\* Halfen clutches carry a CE mark, more information is available on request.

A 5 tonne remote release Locking Klaw is also available which is ideal for tilt-up construction.

Product Description	Part Code
5 Tonne Remote Release	05LKRR

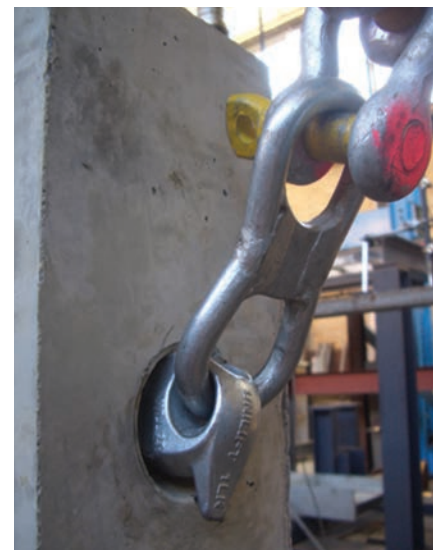

# Unilift Lifting Systems

## Cone Anchors

This classic spherical-headed, forged foot anchors are the first choice for most applications. They are manufactured from hot-dip galvanised, forged, high impact strength construction steel. Genuine Unilift anchors are stamped with a 'U' on the head, as well as load class and length.

The Working Load Limit (Load Class) of Unilift CA Cone Anchors is based on a factor of safety of 3.0. This exceeds the working load limit factor FoS for cast-in lifting inserts of 2.25 as specified in AS 3850.1:2015 - table 2.1.

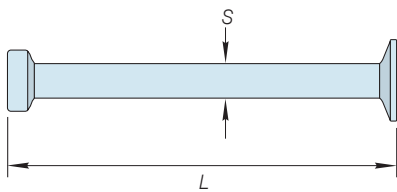

### Part Codes, Dimensions and Pack Size

Load Class (Tonnes)	Dimensions (mm)		LK Locking Klaw	Part Code	Quantity per Bag
	L	S			
1.3	35	10	01LK	CA01035	200
	45	10	01LK	CA01045	200
	55	10	01LK	CA01055	200
	65	10	01LK	CA01065	200
	85	10	01LK	CA01085	100
	120	10	01LK	CA01120*	100
2.5	240	10	01LK	CA01240	50
	55	14	02LK	CA02055	100
	75	14	02LK	CA02075	100
	85	14	02LK	CA02085*	50
	120	14	02LK	CA02120*	50
	170	14	02LK	CA02170*	25
5.0	280	14	02LK	CA02280	25
	75	20	05LK	CA05075	50
	95	20	05LK	CA05095	50
	120	20	05LK	CA05120*	25
	150	20	05LK	CA05150	25
	170	20	05LK	CA05170*	25
10.0	240	20	05LK	CA05240*	20
	340	20	05LK	CA05340	10
	960	20	05LK	CA05960	1
20.0	150	28	10LK	CA10150*	10
	200	28	10LK	CA10200*	10
	340	28	10LK	CA10340*	5
32.0	200	39	20LK	CA20200*	1
	340	39	20LK	CA20340*	1
32.0	500	39	20LK	CA20500	1
	500	50	32LC	CA32500	1
	700	50	32LC	CA32700	1

\* Type 316 stainless steel anchors in stock, other sizes on request.



**COMPLIANT**  
AS 3850.1:2015

## Unilift RA Reo (Eye) Anchors

Unilift RA Reo Anchors are used with a hanger bar, also known as a tension bar, where the concrete is too weak for a cone anchor. They are ideal for thin panels and other applications where the concrete cone developed by traditional foot anchors is insufficient to provide the working load limit of the anchor.

The bar is threaded through the hole in the anchor and embedded deep in the concrete. Like Unilift CA Cone Anchors they are manufactured from hot-dip galvanised, forged, high impact strength construction steel, and are stamped with a Unilift 'U', the load class and length.

The Working Load Limit (Load Class) of Unilift RA Reo Anchors is based on a factor of safety of 3.0. This exceeds the working load limit factor FoS for cast-in lifting inserts of 2.25 as specified in AS 3850.1:2015.

The cut lengths for the hanger bar given in the table are suitable for 15MPa concrete and calculated in accordance with AS 3600:2018 - Concrete Structures based on a FoS of 2.25.

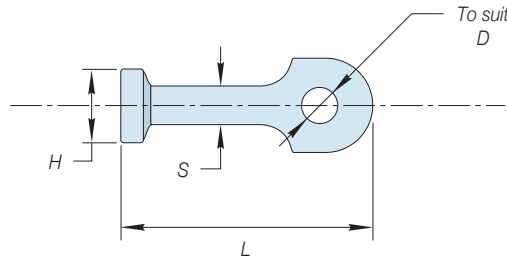

Load Class (Tonnes)	Dimensions (mm)			HL	Bending Diameter $d_i$	Part Code	Quantity per Bag
	L	S	D				
1.3	50	10	R10	500*	50	RA01050	200
	65	10	R10	500*	50	RA01065	200
2.5	65	14	N10	620	50	RA02065	100
	90	14	N10	620	50	RA02090	100
5.0	120	20	N16	840	80	RA05120	25
10.0	180	28	N20	1330	100	RA10180	10
20.0	250	39	N28	2030	140	RA20250	1
32.0	300	50	N40	2600	200	RA32300	1

\* Development length of plain bar increased by factor of 1.5 in accordance with AS 3600

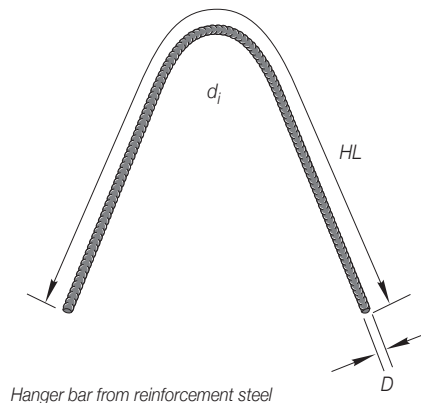

# Unilift Lifting Systems

## Unilift Recess Formers

These products are used to accurately and reliably set the anchor into its recess in the concrete panel. Recess formers are non-interchangeable between load groups to minimise errors and are available in a variety of types to meet the demands of different applications.

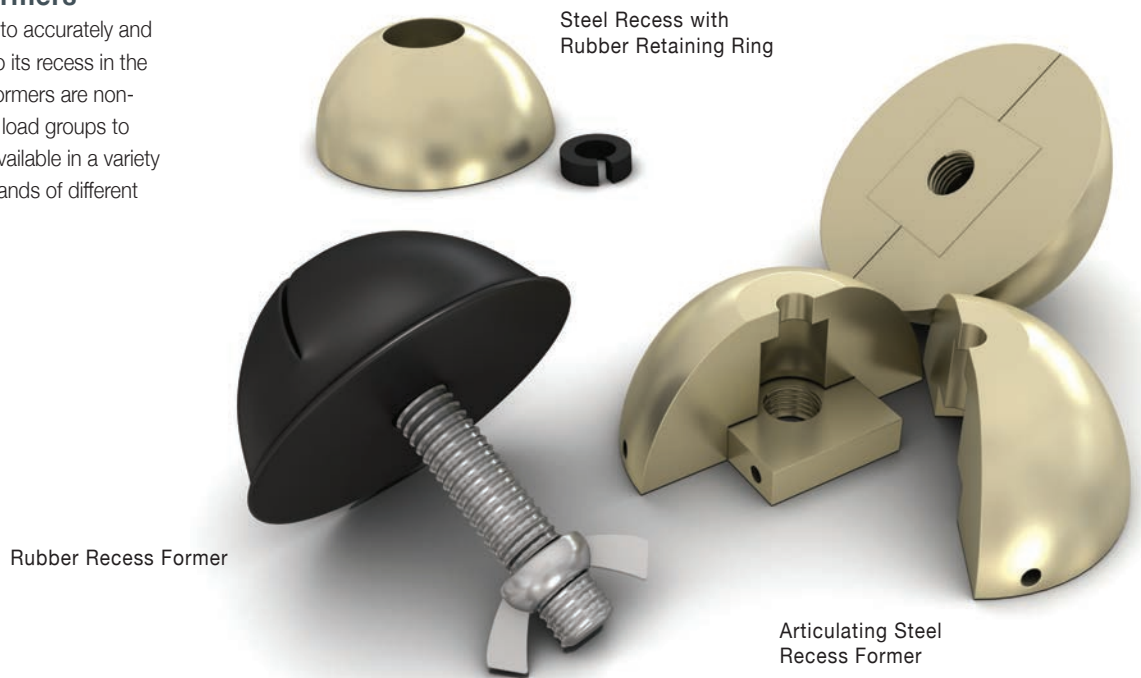

### Rubber Recess Former

Our most economical recess former, used for a wide variety of applications. Made from a hard, yet flexible, oil resistant rubber, they are ideal for attachment to steel and timber forms as well as floats for top surface installation. Supplied complete with attachment bolt and wing nut.

Unilift / Anchor WLL (Tonne)	Diameter (mm)	Part Code
1.3	66	RRF01
2.5	80	RRF02
5	100	RRF05
10	128	RRF10
20	170	RRF20
32	236	RRF32

### Steel Recess with Rubber Retaining Ring

Featuring a replaceable rubber retaining ring, these steel recess formers offer a long service life and are an economical alternative to rubber recesses for production precasting.

Unilift / Anchor WLL (Tonne)	Diameter (mm)	Recess Part Code	Ring Part Code
1.3	60	SRF01	RR01
2.5	74	SRF02	RR02
5.0	94	SRF05	RR05
10.0	130	SRF10	RR10

### Articulated Steel Recess Former

These products are similar in action to the semi-spherical rubber recess, but are manufactured from steel, offering a long service life for production precasting.

Unilift / Anchor WLL (Tonne)	Diameter (mm)	Part Code
1.3	60	SRF01A
2.5	74	SRF02A
5.0	94	SRF05A
10.0	130	SRF10A



### Halfen Magnetic Recess Formers

These magnetic recess formers are used in metal formwork when drilling is not an option.

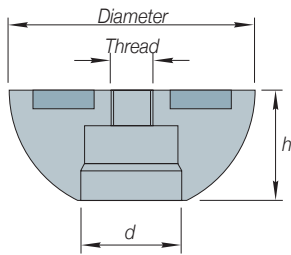

Unilift / Anchor WLL (Tonne)	Part Code	Diameter (mm)	h (mm)	Thread	d (mm)
1.3	SRFM01	60	27.5	M8	20.5
2.5	SRFM02	74	33	M12	30
5.0	SRFM05	94	42	M12	38
10.0	SRFM10	118	53	M12	48



Halfen Magnetic Recess Formers

### Tilt-Up Site Cast Lifting Systems

These systems use the forged steel Unilift 5 tonne anchor and can be used with the remote release 5 tonne QwikTilt Klaw for maximum efficiency on site.

#### QwikTilt Face Lift Anchor Sets

The anchor is housed in a robust plastic chair with four stable legs and several tie-in points on the ring to prevent movement during casting. There is no requirement for a cross bar. They are available from stock, in pre-packed cartons, to suit the most popular panel thickness i.e. 125, 150, 170, 175, 200, 250mm. Units to suit other panel thicknesses are available on request.

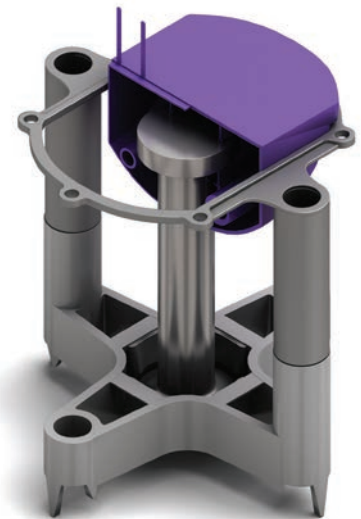

Panel Thickness (mm)	Anchor Length (mm)	Embedment Depth $h_{eff}$ (mm)	Part Code	Quantity per Box
100	75	86	FLA05100	40
125	95	106	FLA05125	40
150	120	131	FLA05150	40
170			FLA05170	30
175			FLA05175	30
200	150	161	FLA05200	25
250			FLA05250	-

## Worldwide contacts for Leviat:

### Australia

**Leviat**  
98 Kurrajong Avenue,  
Mount Druitt Sydney, NSW 2770  
Tel: +61 - 2 8808 3100  
Email: info.au@leviat.com

### Austria

**Leviat**  
Leonard-Bernstein-Str. 10  
Saturn Tower, 1220 Wien  
Tel: +43 - 1 - 259 6770  
Email: info.at@leviat.com

### Belgium

**Leviat**  
Industrielaan 2  
1740 Ternat  
Tel: +32 - 2 - 582 29 45  
Email: info.be@leviat.com

### China

**Leviat**  
Room 601 Tower D, Vantone Centre  
No. A6 Chao Yang Men Wai Street  
Chaoyang District  
Beijing · P.R. China 100020  
Tel: +86 - 10 5907 3200  
Email: info.cn@leviat.com

### Czech Republic

**Leviat**  
Business Center Šafránková  
Šafránková 1238/1  
155 00 Praha 5  
Tel: +420 - 311 - 690 060  
Email: info.cz@leviat.com

### Finland

**Leviat**  
Vädursgatan 5  
412 50 Göteborg / Sweden  
Tel: +358 (0)10 6338781  
Email: info.fi@leviat.com

### France

**Leviat**  
6, Rue de Cabanis  
FR 31240 L'Union  
Toulouse  
Tel: +33 - 5 - 34 25 54 82  
Email: info.fr@leviat.com

### Germany

**Leviat**  
Liebigstrasse 14  
40764 Langenfeld  
Tel: +49 - 2173 - 970 - 0  
Email: info.de@leviat.com

### India

**Leviat**  
309, 3rd Floor, Orion Business Park  
Ghodbunder Road, Kapurbawdi,  
Thane West, Thane,  
Maharashtra 400607  
Tel: +91 - 22 2589 2032  
Email: info.in@leviat.com

### Italy

**Leviat**  
Via F.lli Bronzetti 28  
24124 Bergamo  
Tel: +39 - 035 - 0760711  
Email: info.it@leviat.com

### Malaysia

**Leviat**  
28 Jalan Anggerik Mokara 31/59  
Kota Kemuning, 40460 Shah Alam  
Selangor  
Tel: +603 - 5122 4182  
Email: info.my@leviat.com

### Netherlands

**Leviat**  
Oostermaat 3  
7623 CS Borne  
Tel: +31 - 74 - 267 14 49  
Email: info.nl@leviat.com

### New Zealand

**Leviat**  
2/19 Nuttall Drive, Hillsborough,  
Christchurch 8022  
Tel: +64 - 3 376 5205  
Email: info.nz@leviat.com

### Norway

**Leviat**  
Vestre Svanholmen 5  
4313 Sandnes  
Tel: +47 - 51 82 34 00  
Email: info.no@leviat.com

### Philippines

**Leviat**  
2933 Regus, Joy Nostalg,  
ADB Avenue  
Ortigas Center  
Pasig City  
Tel: +63 - 2 7957 6381  
Email: info.ph@leviat.com

### Poland

**Leviat**  
Ul. Obornicka 287  
60-691 Poznań  
Tel: +48 - 61 - 622 14 14  
Email: info.pl@leviat.com

### Singapore

**Leviat**  
14 Benoi Crescent  
Singapore 629977  
Tel: +65 - 6266 6802  
Email: info.sg@leviat.com

### Spain

**Leviat**  
Polígono Industrial Santa Ana  
c/ Ignacio Zuloaga, 20  
28522 Rivas-Vaciamadrid  
Tel: +34 - 91 632 18 40  
Email: info.es@leviat.com

### Sweden

**Leviat**  
Vädursgatan 5  
412 50 Göteborg  
Tel: +46 - 31 - 98 58 00  
Email: info.se@leviat.com

### Switzerland

**Leviat**  
Grenzstrasse 24  
3250 Lyss  
Tel: +41 - 31 750 3030  
Email: info.ch@leviat.com

### United Arab Emirates

**Leviat**  
RA08 TB02, PO Box 17225  
JAFZA, Jebel Ali, Dubai  
Tel: +971 (0)4 883 4346  
Email: info.ae@leviat.com

### United Kingdom

**Leviat**  
President Way, President Park,  
Sheffield, S4 7UR  
Tel: +44 - 114 275 5224  
Email: info.uk@leviat.com

### United States of America

**Leviat**  
6467 S Falkenburg Rd.  
Riverview, FL 33578  
Tel: (800) 423-9140  
Email: info.us@leviat.us

### For countries not listed

Email: info@leviat.com

**Leviat.com**

#### Notes regarding this catalogue

© Protected by copyright. The construction applications and details provided in this publication are indicative only. In every case, project working details should be entrusted to appropriately qualified and experienced persons. Whilst every care has been exercised in the preparation of this publication to ensure that any advice, recommendations or information is accurate, no liability or responsibility of any kind is accepted by Leviat for inaccuracies or printing errors. Technical and design changes are reserved. With a policy of continuous product development, Leviat reserves the right to modify product design and specification at any time.

**For more information on the following products, please contact:**

**Masonry, Structural and  
Precast Concrete products:**

Tel: 1300 304 320  
Email: [info.ancon.au@leviat.com](mailto:info.ancon.au@leviat.com)  
Web: [Ancon.com.au](http://Ancon.com.au)

**Concrete Floor Jointing  
products:**

Tel: 1800 335 215  
Email: [info.connolly.au@leviat.com](mailto:info.connolly.au@leviat.com)  
Web: [Connollykeyjoint.com](http://Connollykeyjoint.com)

**Remedial Masonry  
products:**

Tel: 1300 667 071  
Email: [info.helifix.au@leviat.com](mailto:info.helifix.au@leviat.com)  
Web: [Helifix.com.au](http://Helifix.com.au)

Email: [info.isedio.au@leviat.com](mailto:info.isedio.au@leviat.com)  
Web: [Isedio.com.au](http://Isedio.com.au)

**General Enquiries**

Tel: 1300 304 320  
Email: [info.au@leviat.com](mailto:info.au@leviat.com)  
Web: [Leviat.com](http://Leviat.com)

**Sales Offices and Production**

**New South Wales, Sydney**

98 Kurrajong Avenue  
Mount Druitt | Sydney  
NSW 2770

**New South Wales, Casino**

10 Irving Drive  
Casino  
NSW 2470

**Victoria**

9/63-69 Pipe Road  
Laverton North | Melbourne  
VIC 3026

**Queensland**

4/15 Terrace Place  
Murarrie | Brisbane  
QLD 4172

**Western Australia**

18 Tennant Street  
Welshpool | Perth  
WA 6106

**Leviat.com**

---

**Leviat**<sup>®</sup>  
A CRH COMPANY

**Imagine. Model. Make.**

**Leviat.com**